

FORM C - OBJECT

MASSACHUSETTS HISTORICAL COMMISSION
 MASSACHUSETTS ARCHIVES BUILDING
 220 MORRISSEY BOULEVARD
 BOSTON, MASSACHUSETTS 02125

Assessor's number USGS Quad Area(s) Form Number

31/117/1

Billerica

930

Town Chelmsford

Place (neighborhood or village) Chelmsford

Address or Location 2 Old North Rd.
 (unaccepted street probably)

Name Chelmsford Police Officers' Monument

Ownership Public Private

Type of Object (check one).

- statue
- bust
- group composition
- religious shrine
- boundary marker
- other (specify)
- monument
- milestone
- marker

Date of Construction May 18, 2003 dedicated

Designer/Sculptor Chief Raymond McCusker

Materials Chelmsford light gray granite
 from Fletcher's Quarry, Westford

Alterations (with dates) none

Condition excellent

Moved no yes Date

Acreage 3.40 acres

Setting open plaza in front of 2003 police station,
 overlooking 1 Old North Rd. in front (west) and McCarthy
 School on south side.

Recorded by Jane B. Drury

Organization for Chelmsford Historical Commission

Date (month/year) Sept. 2003

Photograph

(2" x 3" or 3-1/2" x 5' black and white only)



Sketch Map

Draw a map showing the object's location in relation
 to the nearest cross streets and/or major natural
 features. Show all buildings between object and
 nearest intersection or natural feature. Label streets
 and buildings if any. Circle and number

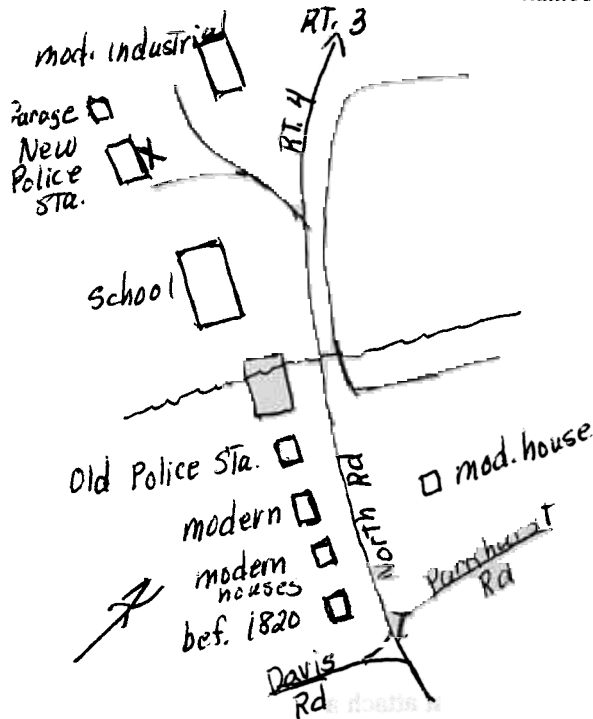

OBJECT FORM

DESIGN ASSESSMENT see continuation sheet

Describe the design features of the object, and evaluate in terms of other similar types of objects within the community.

This large granite monument, 70 inches high, impressively overlooks a building at #1 Old North Road, and also the McCarthy School to the south. Although the design of the stone itself is similar to several other monuments in Chelmsford, it is much larger. The monument shape is similar to the veterans' monuments located in the nearby veterans' Park. The principal reason for the pointed top was to accommodate the engraved police badge.

The monument was designed by Chief Raymond G. McCusker of the Chelmsford Police Department. The stone is 5'6" tall, 4'0" wide and comes to a point; the monument sits on a 5' long by 1'4" x 8" base. The engraved design at the point of the monument is a Chelmsford Police badge. In lieu of placing a rank on the badge the word Honor was inscribed in its place. This reflects the inscription authored by Chief McCusker and written on the monument.

HISTORICAL NARRATIVE see continuation sheet

This monument was erected to honor the men and women who dedicated their lives to police service within the Town of Chelmsford. Chief Raymond McCusker commissioned Mr. Alfred Garside of Westford, MA to construct the monument. Mr. Garside also constructed the granite Police patch located on the floor of the station lobby as well as the full color granite Town seal located on the front of the building and the granite sign located at the entrance. All of these granite items are made from Chelmsford gray granite obtained from Fletchers' Quarry in Westford, MA.

The dedication of the monument took place on the same day that of the new police station grand opening. Ceremonies for both events were combined and took place in the station's courtyard and began with remarks made by Chief McCusker. "The Chelmsford Police Honor Guard joined five of their Chelmsford, England counterparts in honoring the men and women who have served, and continue to serve, the town as police officers by placing a wreath on the monuments." Speeches by various dignitaries from both countries followed. The monument will also be the site for remembrance of Chelmsford's first and only officer killed in line of duty, Donald F. Adams.

ENTIRE INSCRIPTION (if applicable):

Honor
Police
[town motto design in shield]
CHELMSFORD

Dedicated to Officers past and present
who protect and serve our community with
integrity and honor

May 18, 2003

[On bronze plate on monument base]

Donated by the
Chelmsford Police
Foundation

BIBLIOGRAPHY and/or REFERENCES see continuation sheet

Annual Report of the Town of Chelmsford, Year ending December 31, 1927, pg. 151
Chelmsford Independent, May 22, 2003, by Kevin Zimmerman, Staff Writer, pg. 1, 16
Lowell Courier-Citizen, July 20, 1927, pg. 1, 3
Police Chief Raymond McCusker, June 2003
Chelmsford Assessors' records

Recommended for listing in National Register of Historic Places. If checked, you must attach a completed National Register Criteria Statement form.

INVENTORY FORM CONTINUATION SHEET

MASSACHUSETTS HISTORICAL COMMISSION
MASSACHUSETTS ARCHIVES BUILDING
220 MORRISSEY BOULEVARD
BOSTON, MASSACHUSETTS 02125

Town
CHELMSFORD

Property Address
2 OLD NORTH RD.

Area(s) Form No.

	930
--	-----

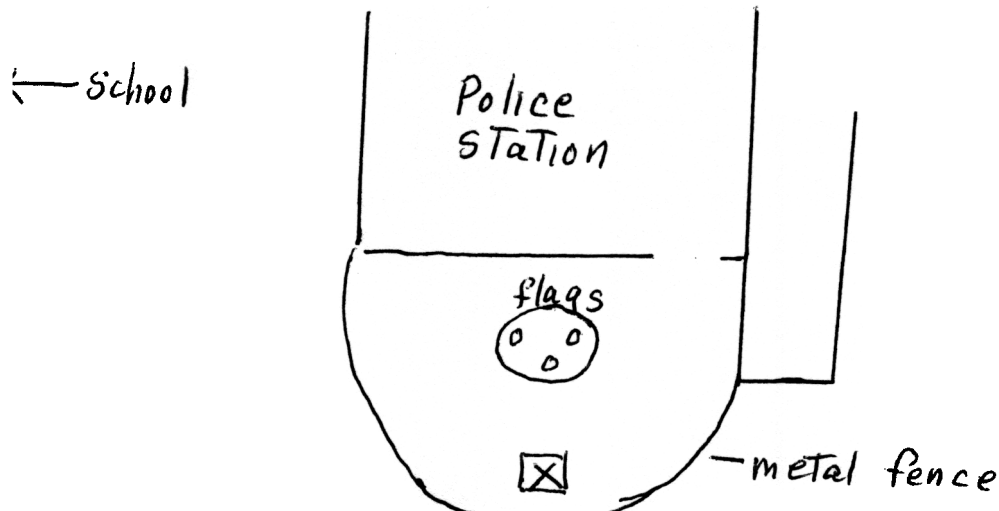
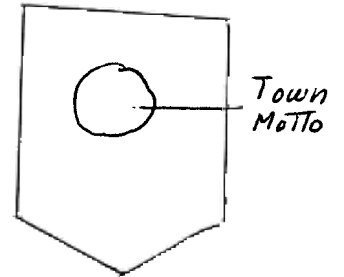
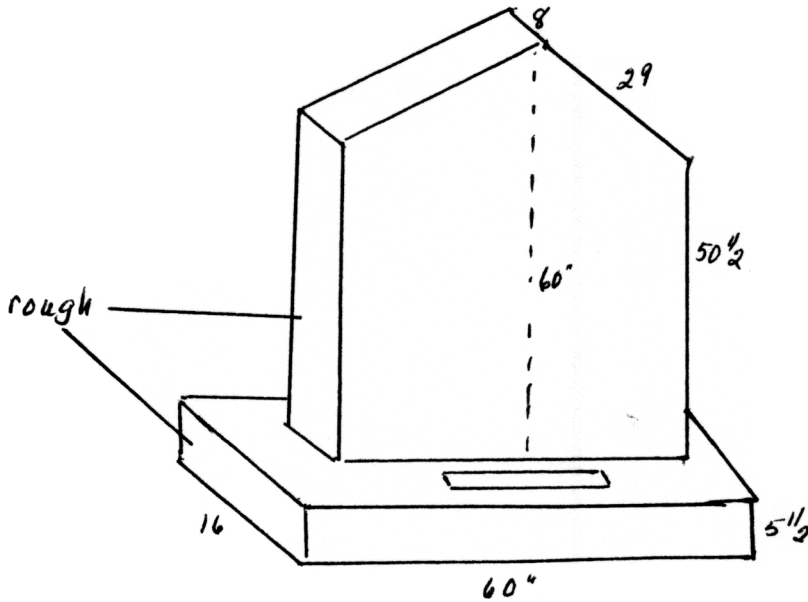



'Chelmsford Police Officers' Monument' Station Dedication Day

5/18/2003 F Merriam

